



## Transmission Installation Instructions

Slash 2WD, Electric Stampede 2WD, Electric Rustler & Bandit

### Step 1:

Remove the stock transmission from the vehicle and save the screws as they will be reused. Place the pre-built transmission into the vehicle and assemble the bottom screws as shown.

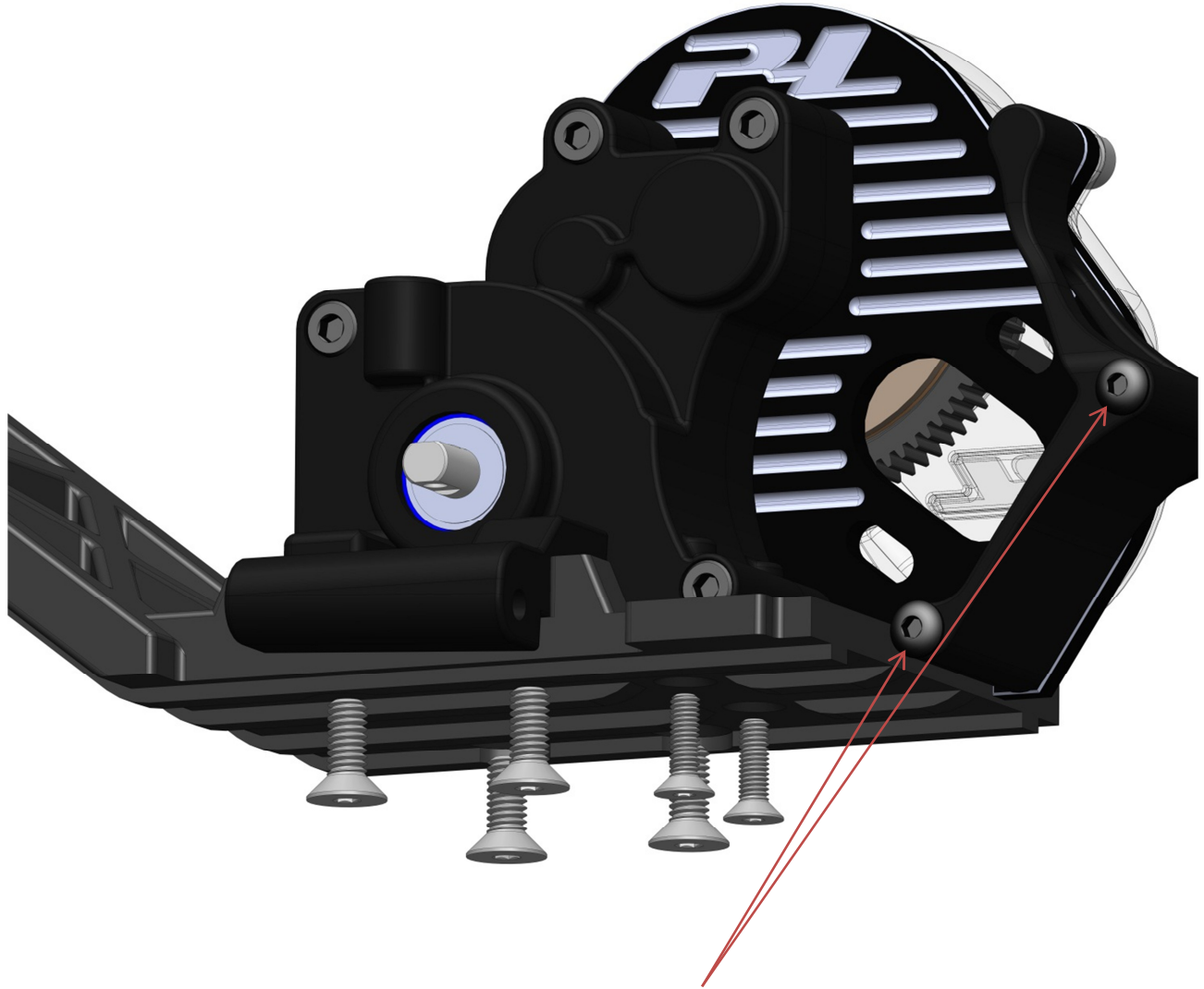

**\*Slash Requires removal of these screws before installation\***

**Step 2:**

Secure the Transmission to the Shock Tower with screws as shown.

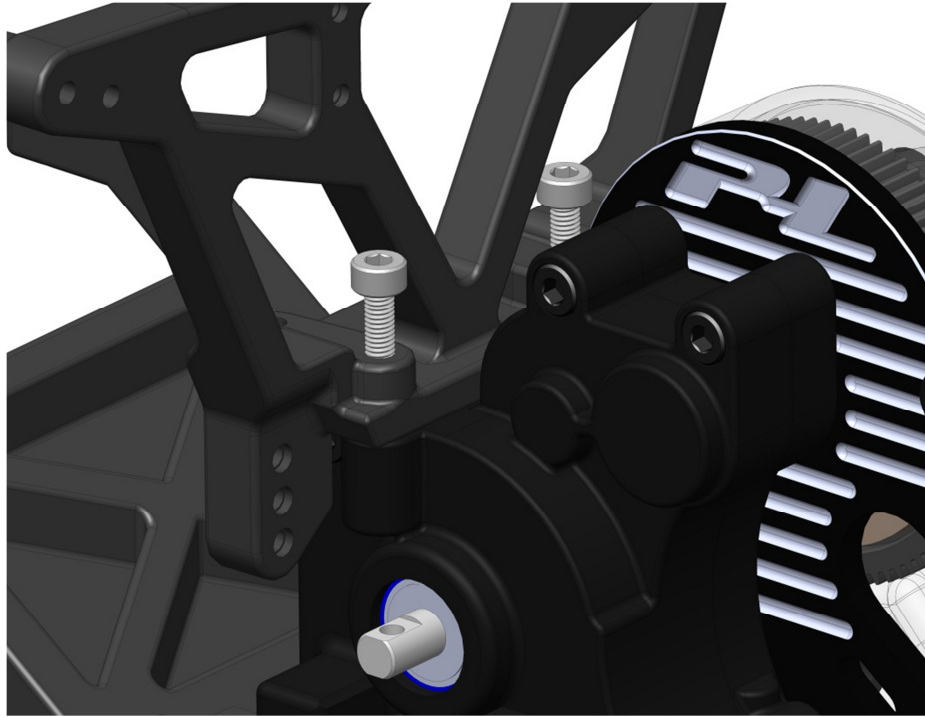

**Step 3:**

Place the Outdrive Shim (located in the separate Hardware Bag) over the Outdrive Shaft and install the Outdrive and Drive shaft. Repeat for the other side. **Racing style Outdrives shown below but Stock Outdrives will also work.**

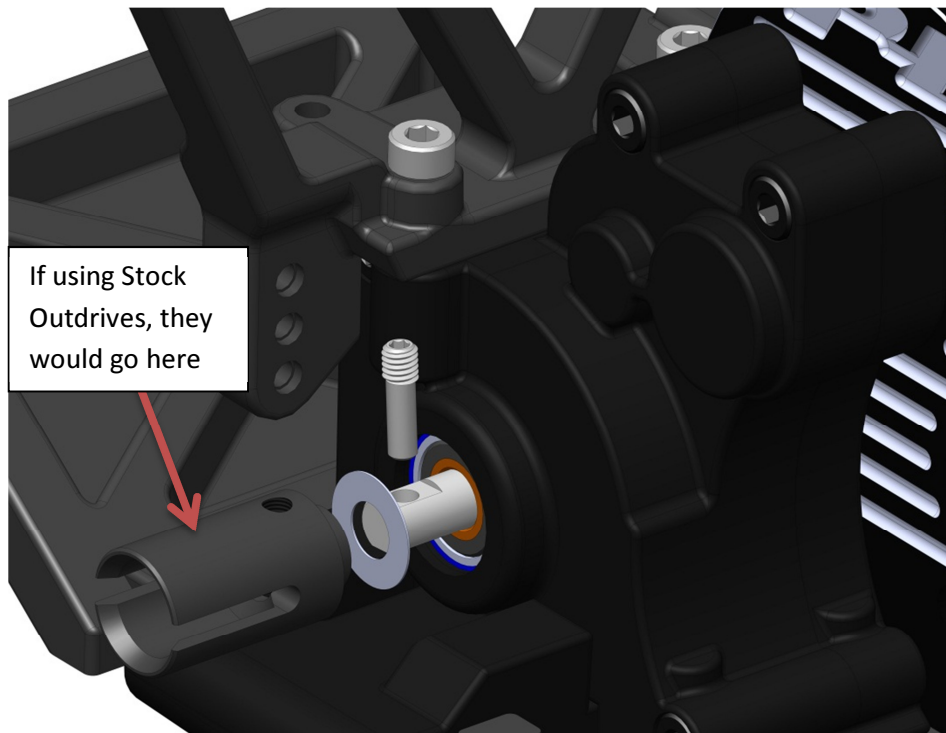

**Step 4:**

Install rear arms onto the Toe Block with the Hinge Pins. Make sure the drive shafts are installed into the drive cup or spline before completing installation.

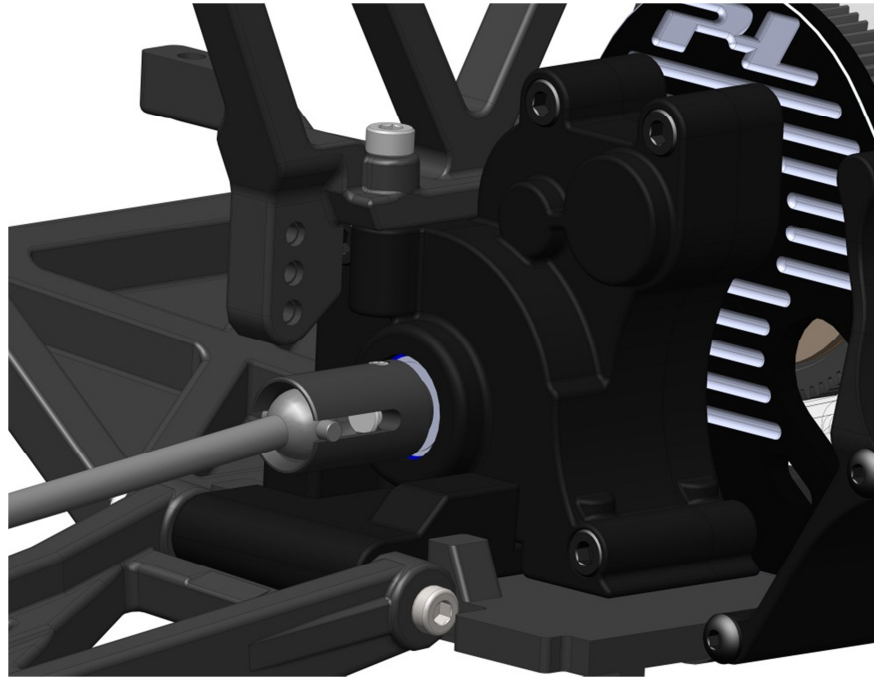

**Step 5:**

Remove the gear cover from the transmission by unscrewing the two screws as shown. Place the motor into the transmission and locate the motor screws and motor screw washers included in the separate Hardware Bag.

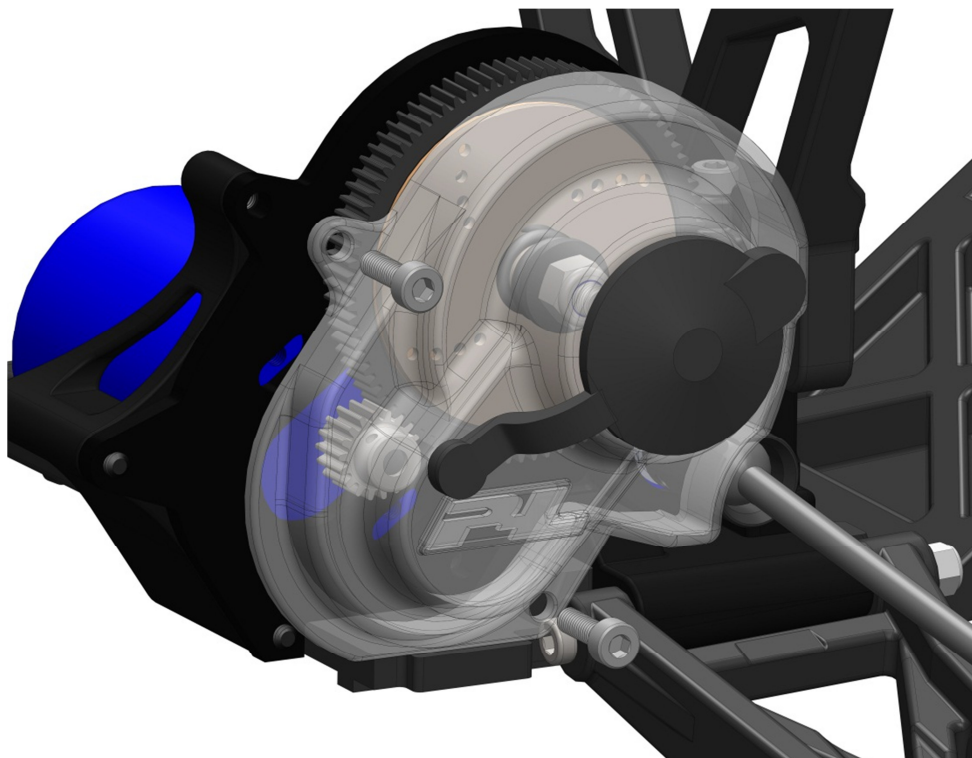

### Step 6:

Place the motor screw washers over the motor screws and install the motor as shown. Set the gear mesh properly as described in the Traxxas® Users Manual.

**\*Note: Bandit Requires Smaller Pinion Gear than Stock. Recommend 18t or 19t for most motor applications.\***

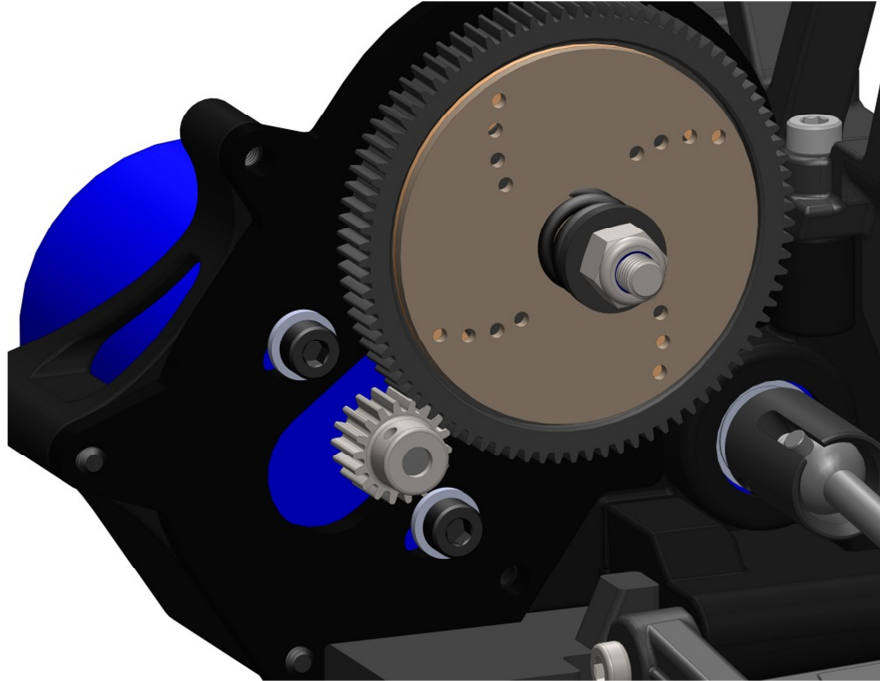

### Step 7:

Install the Gear Cover as shown. Do Not over-tighten the screws.

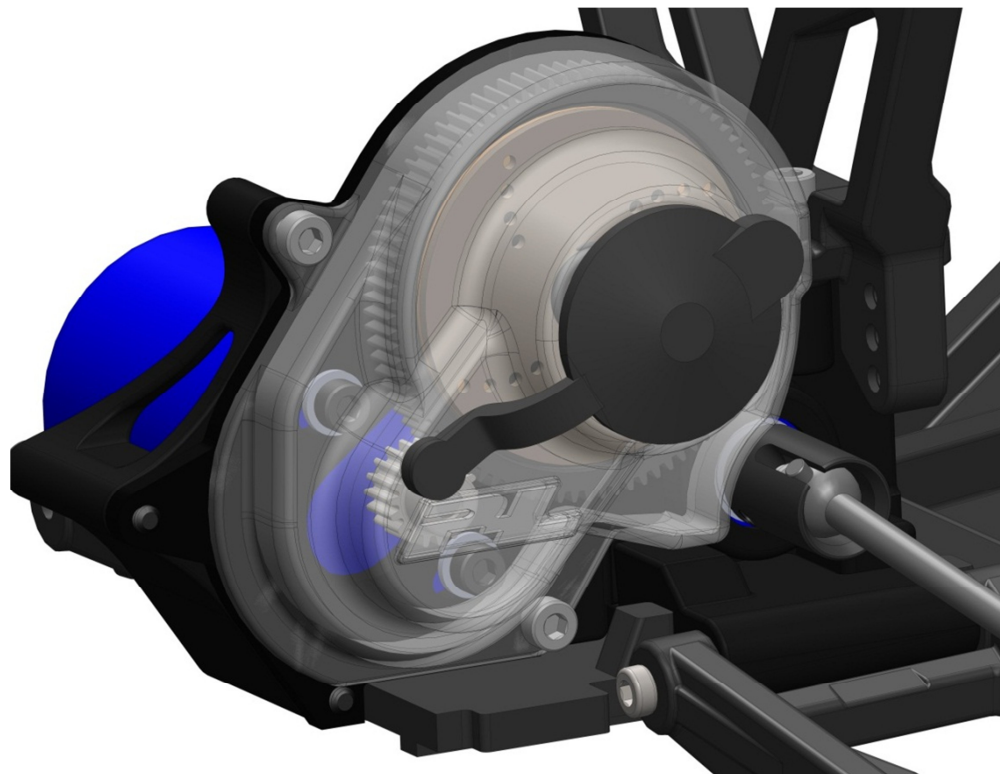

→Installation is Complete for Rustler, Bandit & Stampede (without Wheelie Bar)! Enjoy the Improved Performance!

↓Continue for Slash 2WD Bumper and Stampede 2WD Wheelie Bar Installation

**Step 8:**

Locate the 2 Long screws and Spacer in the separate Hardware Bag. These will be used to attach the bumper/wheelie bar to the transmission.

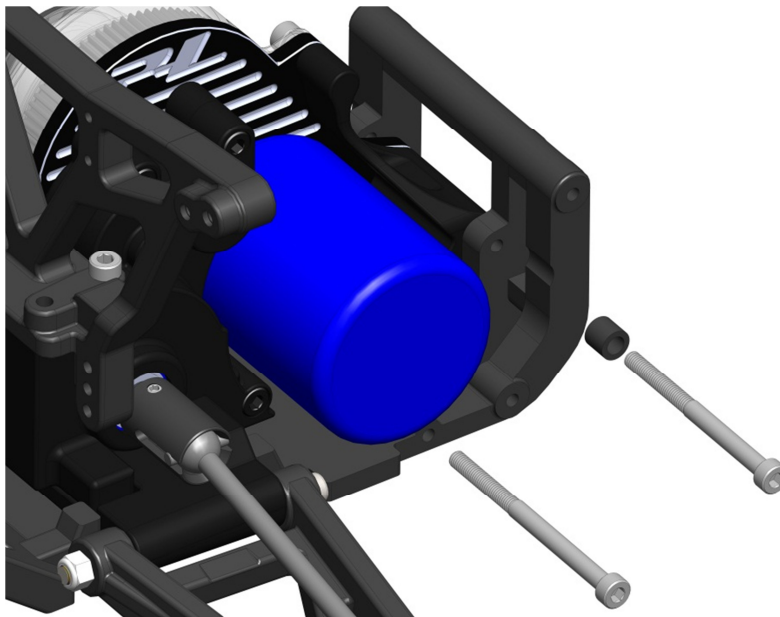

**Step 9:**

Install the longer of the 2 screws into the bottom as shown all the way through to the Aluminum Motor Mount. Use Blue Thread Locking Compound for security.

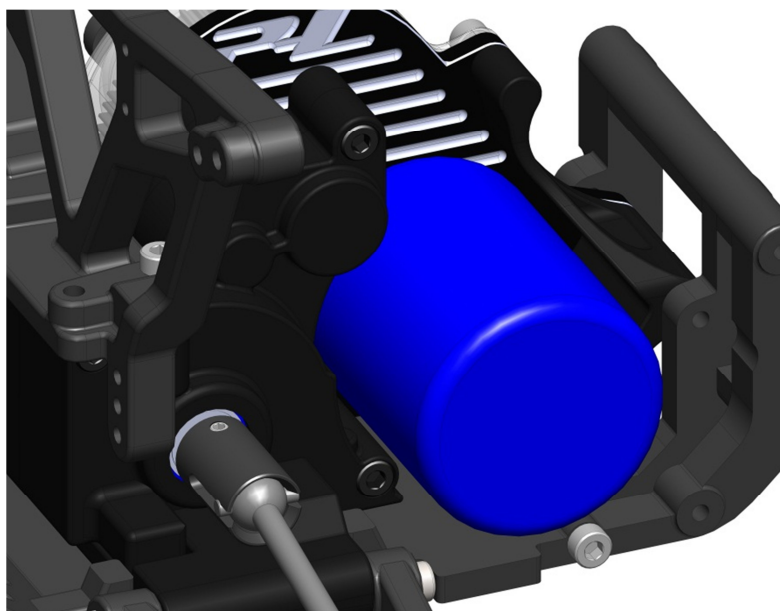

**Step 10:**

Place the Spacer in between the motor plate and the Bumper/wheelie bar gap and install the screw as shown. Pre-threading the plastic will ease installation.

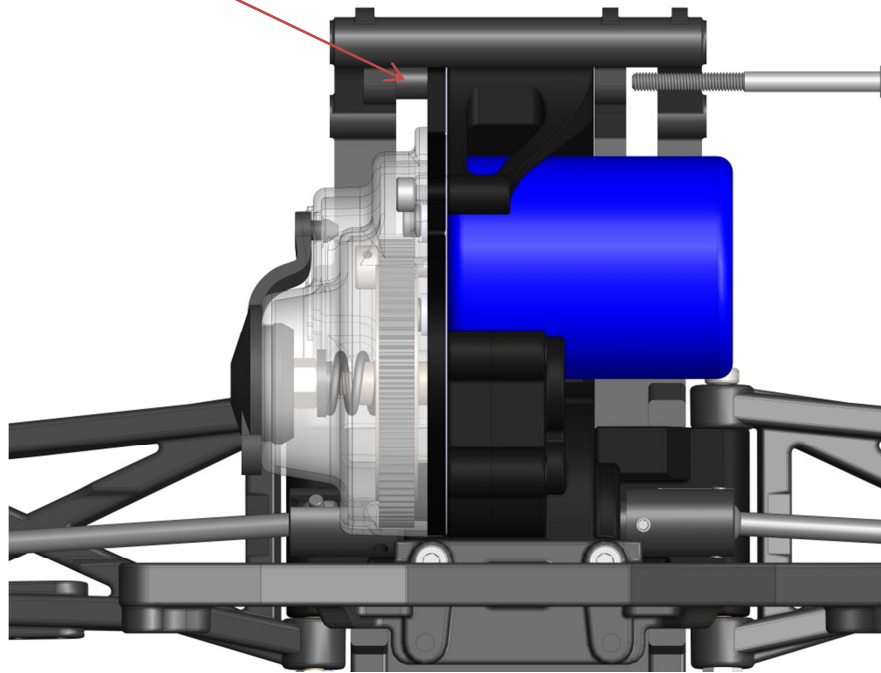

**Step 11:**

Finish Installing the rest of the Bumper/Wheelie Bar as your vehicle manual requires. Congratulations on your new Pro-Line Performance Transmission!

